

| | |
|--------------------|-----------------------------|
| Heat Output | 280–300m² |
| Avg Efficiency | 72% |
| Max Efficiency | 75% |
| Emissions | 1.0 gm/kg |
| Burn Time | 10-14 hours |
| Log Size (max) | 450mm |
| Weight | 277kg |

NEO RANGE FP25 ZERO CLEARANCE

HIGH EFFICIENT WOOD HEATERS

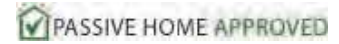

The FP25 is the first passive home approved inbuilt wood heater. Outside air brings air into the heater, and the insulated flue keeps the heat in the room.

Purpose built to be zero clearance, the FP25 can be installed into any home, not just into a pre-existing fireplace.

Pacific Energy has included the latest technology, including a draft breaker for high ceilings, a dual speed automatic fan, and a fully stainless-steel baffle that returns the smoke.

The FP25 isn't just a wood heater – it's an advanced heating system combining innovation, efficiency, and design to offer unmatched comfort and performance.



STANDARD

- Steel Firebox with 8mm thick steel: 10 year warranty
- 304 grade Stainless Steel Baffle: 10 year warranty
- Cast Iron Door: With roller door handle for ease of closing
- Wide Firebox: Takes 400mm long wood
- True Slow Combustion: Offering overnight burn

- EBT: Automatic draft breaker, perfect for homes with excess flue
- Clean Glass Tech: Turbulent air wash for cleaner glass
- Direct Air: Bellow air direct into coals for fast lighting
- Fully fire bricked lined
- 2 Fans: Automatically Controlled
- Zero Clearance: Perfect for a new install

ADD-ONS

+ Outside Air Adapter: Perfect for new homes

Ducting Kit: 2+ optional ducts can be added

DIMENSIONS

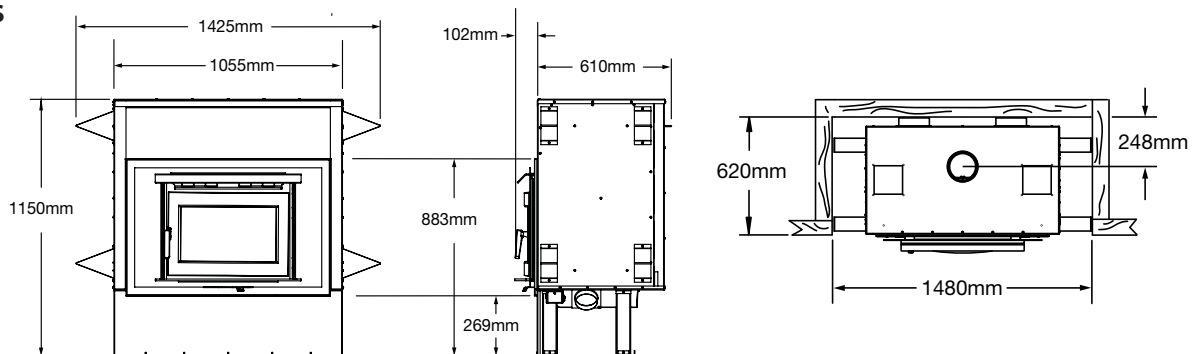

ZERO CLEARANCE FRAMING

- Cavity Height: 1600 mm
- Cavity Width: 1480 mm
- Cavity Depth: 610 mm

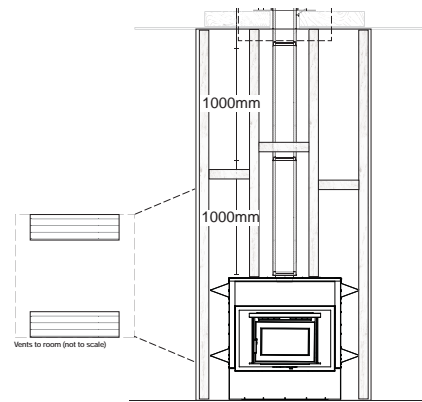
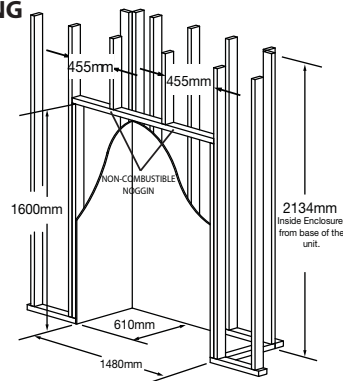

Paint Finish: Stone Bright Metallic Black